

Stainless Steel Hydrant Valve 90°

FIG. 6702

Specifications

- IAPMO certified, complies to AS 2419.2-2009 Standard.
- Material: CF8/ASTMA743.
- Approve AS 4020 contamination of water.
- Sealing torque 40Nm when pressure 21 bar.
- Body test & seat test 27 bar (2700KPa).
- Pressure retention test 32 bar (3200KPa).
- Temperature Rating -10°C~85°C.
- The outlet can be replaced upon request.
- Forged Storz fitting on landing valve complies with NEN 3374.

Corrosion Protection

- Spray red paint on exterior surface.

Material Specification

Part	Material	ASTM Specification
Body	Stainless Steel	ASTM A743 CF8
Bonnet	Stainless Steel	ASTM A743 CF8
Disc	Stainless Steel	ASTM A743 CF8
Stem	Stainless Steel	ASTM A276 316
Gland Nut	Stainless Steel	ASTM A743 CF8
Storz	Forged Al	
Seal	Rubber EPDM	AS1646 EPDM
Seal Ring	Rubber NBR	AS1646 NBR
Handwheel	Gray Cast Iron	AS1830 T200
Blank Cap	Plastic	
Fasteners	Stainless Steel	A2-70

Outlet Options

Type	Description
1	British instantaneous to BS 336
2	Storz hermaphrodite to DIN 14303
3	64 mm x 4.88 mm pitch (2 1/2x5 1/5 TPI)
4	64 mm x 5.08 Pitch (2 1/2x5 TPI)
5	63 mm x 8.47 Pitch (2 1/2 x 3 TPI)
6	Queensland round thread
7	SA round thread

Schematic

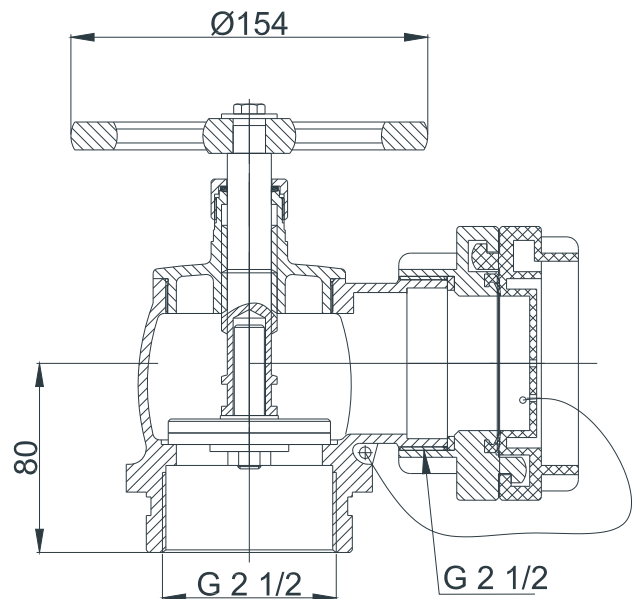
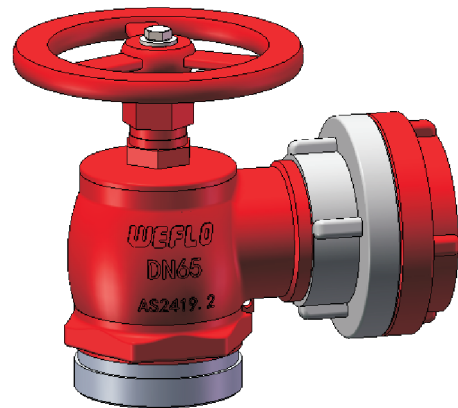

- 80mm Roll Groove with 65mm Threaded BSP

Notes

- Designs, materials and specifications shown are subject to change without notice due to the continuous development of our products.